

Condenser Cleaner

5125 Series

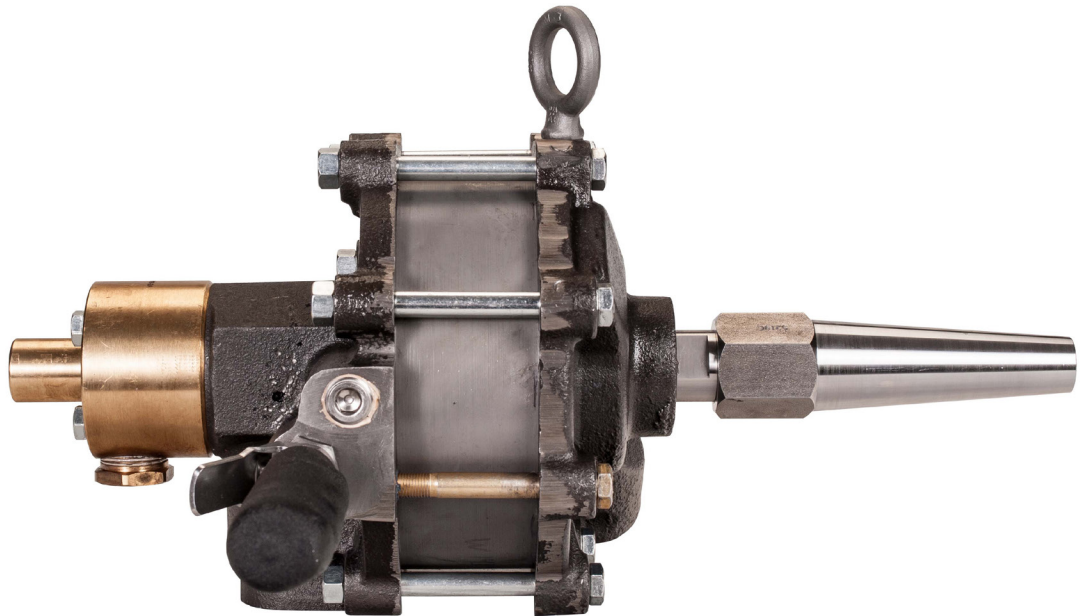

Tube & Pipe Cleaners ◦ Tube Testers ◦ Tube Plugs ◦ Tube Removal ◦ Tube Installation



Operating and Maintenance Instructions

TABLE OF CONTENTS

Introduction 4

Safety Guidelines 5

General Information..... 6

Operation Instructions..... 7

Technical Information 8

Parts List & Diagrams..... 9

Maintenance Instructions 12

Troubleshooting..... 13

Warranty 14

INTRODUCTION

Thank you for purchasing this Elliott product. More than 100 years of experience have been employed in the design and manufacture of this control, representing the highest standard of quality, value and durability. Elliott tools have proven themselves in thousands of hours of trouble-free field operation.

If this is your first Elliott purchase, welcome to our company; our products are our ambassadors. If this is a repeat purchase, you can rest assured that the same value you have received in the past will continue with all of your purchases, now and in the future.

The 5125 Condenser Cleaner has been designed to provide high-torque for cleaning hard scale, coke, gummy, oily, or rubbery deposits. The cleaner is ideal for:

Sugar Mills

Paper Mills

Chemical Plants

Oil Refineries

If you have any questions regarding this product, manual or operating instructions, please call Elliott at +1 800 332 0447 toll free (USA only) or +1 937 253 6133, or fax us at +1 937 253 9189 for immediate service.

SAFETY GUIDELINES

Read and save all instructions. Before use, be sure everyone using this machine reads and understands this manual, as well as any labels packaged with or attached to the machine.

- Know Your Elliott Tool. Read this manual carefully to learn your tool's application and limitations as well as the potential hazards specific to this tool.
- Keep Work Area Clean and Well Lit. Cluttered, dark work areas invite accidents.
- Dress Properly. Do not wear loose clothing or jewelry. Wear a protective hair covering to contain long hair. It is recommended that the operator wear safety glasses with side shields or a full face shield eye protection. Gloves and water repellant, nonskid footwear are also recommended. Keep hands and gloves away from moving parts.
- Use Safety Equipment. Everyone in the work area should wear safety goggles or glasses with side shields complying with current safety standards. Wear hearing protection during extended use, respirator for a confined space and a dust mask for dusty operations. Hard hats, face shields, safety shoes, respirators, etc. should be used when specified or necessary. Keep a fire extinguisher nearby.
- Use The Right Tools. Do not force a tool or attachment to do a job or operate at a speed it was not designed for.
- Use Proper Accessories. Use Elliott accessories only. Be sure accessories are properly installed and maintained.
- Check for Damaged Parts. Inspect guards and other parts before use. Check for misalignment, binding of moving parts, improper mounting, broken parts or any other conditions that may affect operation. If abnormal noise or vibration occurs, turn the tool off immediately and have the problem corrected before further use. Do not use a damaged tool. Tag damaged tools "Do Not Use" until repaired. A damaged part should be properly repaired or replaced by an Elliott service facility. For all repairs, insist on only identical replacement parts.
- Keep Hands Away from All Moving Parts.
- Do Not Overreach. Maintain Control. Keep proper footing and balance at all times.
- Stay Alert. Watch what you are doing, and use common sense. DO NOT use a tool when you are tired, distracted or under the influence of drugs, alcohol or any medication causing decreased control.
- Unplug Tool. Unplug tool when it is not in use, before changing accessories or performing recommended maintenance.
- Maintain Tool Carefully. Keep tools sharp and clean for best and safest performance. Follow instructions for lubrication, maintenance and changing accessories. For more information see "Maintenance" section. Periodically inspect the tool cord and extension cords for damage. Have damaged parts repaired or replaced by an Elliott service facility.
- Store Idle Tools. When not in use, store your tool in a dry, heated, secured place. For more information see "Maintenance" section.
- Maintain Labels and Nameplates. These carry important information and will assist you in ordering spare and replacement parts. If unreadable or missing, contact an Elliott service facility for a replacement.

GENERAL INFORMATION

A clean lubricated air supply must be available at 90 to 125 psi (6.2 to 8.6 Bar), and not less than 175 cfm (5 M³/min.), at the point of connection to the motor. A shut-off valve should be provided at the air supply connection source. If there is any doubt about the cleanliness of the air supply, a filter should be installed at the supply connection.

Motors 512500 & 512500AP (Air Purge) weigh approximately 35 lbs. (15.9 Kg) and it is recommended that an overhead support that allows some maneuverability be made available for ease of handling.

Proper lubrication of the unit is a must for peak performance; therefore, a lubricator (preferably a filter/lubricator) should be installed in the airline immediately downstream of the shut-off valve. For best results, use 10W/NR Lube Oil (PN 900082P), available from Elliott Tool Technologies in 16 oz. (0.5 L) cans.

A clean water supply must be provided (preferably city water). Water pressure should not exceed 125 psi (8.6 Bar). A flow rate of at least 30 gpm (114 L/min.) should be available. A shut-off valve should be at the point of connection of the hose whip to the water source. (IMPORTANT: Never operate Model 512500 tube cleaner without water supply. Running this tool without water will damage the packing and cause immediate tool failure.)

Hose connection for the water feed hose (supplied) is 1/4" N.P.T.. Connection for the air supply hose (optional) is 1" N.P.T.. The hose used on the 512500 motor for the water feed hose is also the same hose as the air feed hose on the 512500AP air-purge motor.

OPERATION INSTRUCTIONS

Set-Up

1. Open the air & water supply valves (air only if air-purge). Holding the motor with the threaded shaft end away from you, slowly depress the trigger lever on the handle (30). The threaded shaft (9) should rotate & water (or air if air-purge) should exit the opening in the threaded shaft. The flow of the water (or air) should increase as the motor R.P.M. increases. If this does not occur, recheck hose connections, or refer to “Troubleshooting” section.
2. After attaching the motor coupling, the motor shafting, the extension shafting (if req’d.), and the cleaning attachment (drill or brush), insert the shaft into the tube I.D.. (NOTE: DO NOT activate the motor while the shaft end is outside the tube. Doing so could result in serious injury.) Maximum length of shafting outside of the tube during the cleaning process is 5 ft. (1.5M).

(NOTE: If tubes are completely blocked by deposit close to the tube sheet, it is recommended that only a 5 ft. (1.5M) motor shaft be used to clean all of the blocked tubes. Additional 5 ft. (1.5M) shaft extensions can be added for deeper cleaning requirements. Operating the cleaner in completely blocked tubes with a shaft length extending outside of the tube greater than 5 ft. (1.5M) from the tube sheet can result in excessive whipping of the shaft, which could cause serious injury to the operator and/or bystanders.) If a length of shafting exceeding 5 ft. (1.5M) must be used then support must be provided for the shafting.

NOTE: DO NOT support shafting with your hands. Keep hands & clothing clear of rotating shaft & components to avoid serious injury. An acceptable means of support for the shafting would be a tube guide that is supported by a height-adjustable stand.

TECHNICAL INFORMATION

Motor Specifications	
Operating Pressure	90 to 125 PSI (6.2 to 8.6 bar)
Air Consumption	175 cfm (5.0M ³ /min) @ 90 PSI (6.2 bar)
Water Pressure	50 PSI (8.6 bar)
Water Flow Rate	30 gpm (114 L/min)
Operating Speed	1600 RPM
Maximum HP	2.1HP @ 1500 RPM
Maximum Torque	8.3 ft. lbs. (11.3Nm) @ 700 RPM
Approximate Weight	35lbs (15.9 Kg)
Overall Length	11" (279.4mm)

PARTS LISTS & DIAGRAMS

512500AP Condenser Cleaner

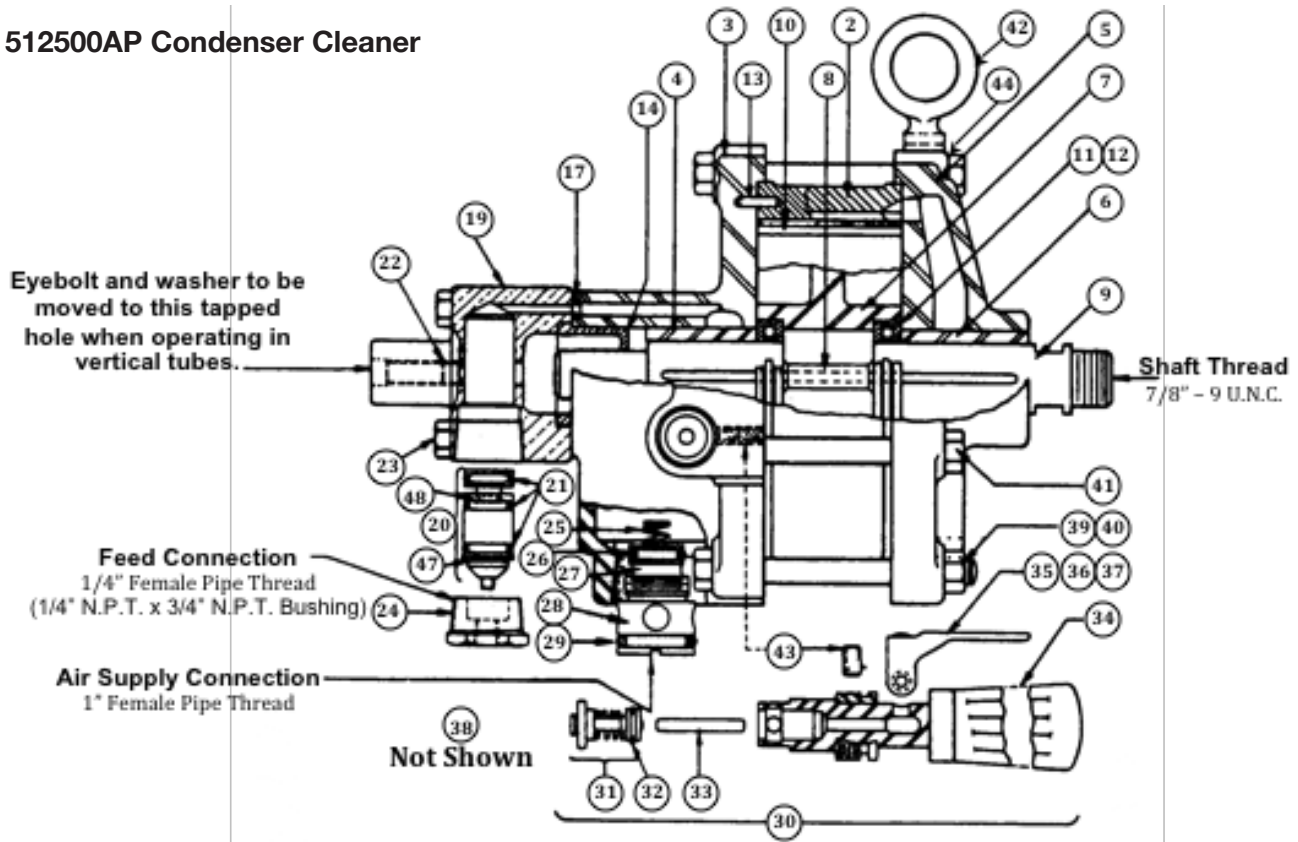

NOTE: Motors with serial number preceding 19289 will be repaired with old style valve. (Detail number 20)

Item #	Item Name	Qty	Part Number
1	Motor Assembled	1	512500AP
2	Body	1	504201
3	Inlet End	1	512502A
4	Inlet End Bushing	1	512503
5	Exhaust End	1	512505
6	Exhaust End Bushing	1	512507
7	Rotor	1	512509
8	Rotor Key	1	512510
9	Shaft	1	512511
10	Paddle Set	1	512513-4
11	Ball Thrust Bearing	2	P112454
12	Ball Thrust Plate	4	512512
13	Dowel	2	P8383-12
14	Packing Box	1	512516
17	Connecting "O" Ring	1	P8309-5
19	Water Feed Valve Body	1	512519-2A
20	Water Feed Valve	1	512520-2
21	Feed Valve "O" Ring	3	P8309-11
22	Valve Unit Set Screw	1	128A
23	Feed Valve Cap Screw	4	130BK
24	Reducing Bushing	1	119N
25	Main Valve Spring	1	P512521

Item #	Item Name	Qty	Part Number
26	Main Valve "O" Ring	1	P8309-13
27	Main Valve	1	512522
28	Main Valve Body	1	512521
29	Valve Body "O" Ring	1	P8309-18
30	Valve Handle Assembled	1	512530
31	Trigger Valve Assembled	1	512540
32	Trigger Valve "O" Ring	1	P8309-7
33	Trigger Valve Push Rod	1	512530E
34	Handle Grip	2	P512527
35	Trigger	1	512530K
36	Trigger Roller	1	512530H
37	Trigger Roller Pin	1	P8383-16
38	Dead Handle	1	512527
39	Body Bolt	6	P8296F
40	Body Bolt Nut	6	171Q
41	Body Cap Screw	2	163CT
42	Eye Bolt	1	512543
43	Valve Handle Lock Screw	2	108N
44	Eye-Bolt Lock Washer	1	133C
45	Shaft Wrench	1	149E
46	"Allen" Wrench	1	P8369E
47	Feed Valve "O" Ring	1	P8309-6
48	Feed Valve "O" Ring	1	P8309-5

PARTS LISTS & DIAGRAMS

512500 Condenser Cleaner

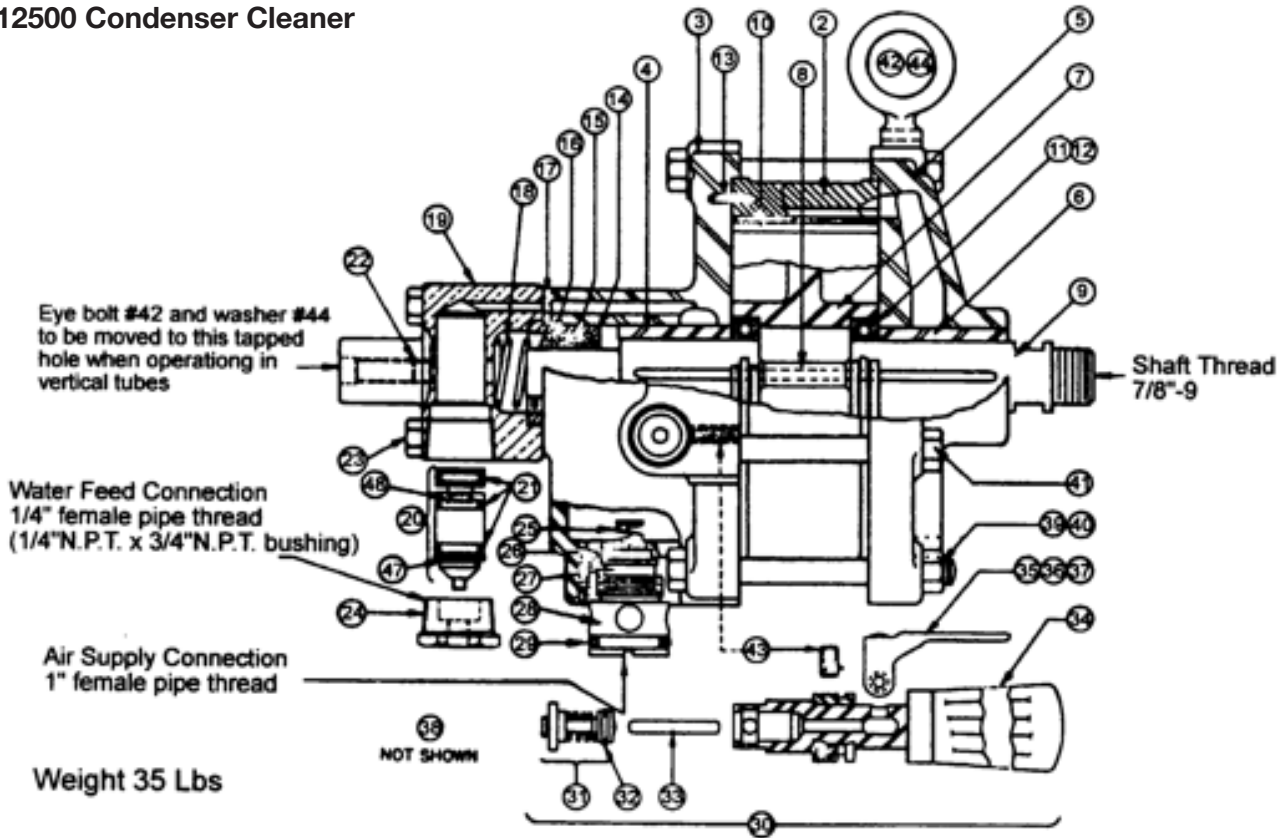

NOTE: motors with serial number preceding 19289 will be repaired with old style valve. (detail number 20)

Item #	Item Name	Qty	Part Number
1	Motor Assembled	1	512500
2	Body	1	504201
3	Inlet End	1	512502A
4	Inlet End Bushing	1	512503
5	Exhaust End	1	512505
6	Exhaust End Bushing	1	512507
7	Rotor	1	512509
8	Rotor Key	1	512510
9	Shaft	1	512511
10	Paddle Set	1	512513-4
11	Ball Thrust Bearing	2	P112454
12	Ball Thrust Plate	4	512512
13	Dowel	2	P8383-12
14	Packing Box	1	512516
15	Packing	2	512531
16	Packing Follower	1	512517
17	Connecting "O" Ring	1	P8309-5
18	Packing Spring	1	P512518
19	Water Feed Valve Body	1	512519-2A
20	Water Feed Valve	1	512520-2
21	Feed Valve "O" Ring	3	P8309-11
22	Valve Unit Set screw	1	128A
23	Feed Valve Cap Screw	4	130BK
24	Reducing Bushing	1	119N

Item #	Item Name	Qty	Part Number
25	Main Valve Spring	1	P512521
26	Main Valve "O" Ring	1	P8309-13
27	Main Valve	1	512522
28	Main Valve Body	1	512521
29	Valve Body "O" Ring	1	P8309-18
30	Valve Handle Assembled	1	512530
31	Trigger Valve Assembled	1	512540
32	Trigger Valve "O" Ring	1	P8309-7
33	Trigger Valve Push Rod	1	512530E
34	Handle Grip	2	P512527
35	Trigger	1	512530K
36	Trigger Roller	1	512530H
37	Trigger Roller Pin	1	P8383-16
38	Dead Handle	1	512527
39	Body Bolt	6	P8296F
40	Body Bolt Nut	6	171Q
41	Body Cap Screw	2	163CT
42	Eye Bolt	1	512543
43	Valve Handle Lock Screw	2	108N
44	Eye-Bolt Lock Washer	1	133C
45	Shaft Wrench	1	149F
46	"Allen" Wrench	1	P8369E
47	Feed Valve "O" Ring	1	P8309-6
48	Feed Valve "O" Ring	1	P8309-5

SHAFTING & COUPLINGS

Motor Coupling - Connects Motor To Motor Shaft



Motor Coupling
Connects to the 5125 or 5224XL cleaner.



Motor Shaft
Connects Motor Coupling to the Extension Coupling.



Extension Coupling
Connects Motor Shaft to the Extension Shaft.



Extension Shaft
Extends the reach of the cleaning tool by 5' (1.5M)

Elliott Tool offers a number of shafts and couplings to be used with the 5224XL and 5125 Heat Exchanger Tube Cleaners to accommodate different tube sizes and tube lengths.

Tube ID Range	Cleaning Shaft OD	*Motor Shaft Part #	Motor Shaft Thread Size	Motor Coupling Part #	**Extension Coupling Gasket Part #	Extension Coupling Part #	Extension Shaft Part #
0.370" - 0.407" (9.40 - 10.32 mm)	5/16" (7.9mm)	5213-(FT)	#10-32 F	5213C			
0.435" - 0.459" (11.05 - 11.66 mm)	3/8" (9.5mm)	5214-(FT)	1/4-20 F	5214C		501406	5014-(FT)
0.481" - 0.560" (12.22 - 14.22 mm)	7/16" (11.1mm)	5215-(FT)	5/16-18 F	5215C	P5034A	CS113106	5015-(FT)
0.584" - 0.685" (14.83 - 16.56 mm)	1/2" (12.7mm)	5216-(FT)	3/8-16 F	5216C	P5034B	CS113206	5016-(FT)
0.709" - 0.810" (18.01 - 20.57 mm)	5/8" (15.9mm)	5218-(FT)		5218C	P5034C	CS113406	5018-(FT)
0.834" - 1.06" (21.18 - 22.91 mm)	3/4" (19.1mm)	5219-(FT)	1/2-13 F	5219C	P5034D	CS113506	5059-(FT)
1.084" - 1.902" (27.53 - 43.31 mm)	7/8" (22.2mm)	5220-(FT)	5/8"-11 F	5220C	P5034E	CS113606	5060-(FT)

*Note: * Specify shaft length in feet (i.e. 5213-5). ** Included with each Extension Coupling, except where noted. For Additional Lengths and Sizes Contact Customer Service.*

How To Order Tube Cleaner Shafting, Accessories, Drills, And Brushes:

1. Measure the tube ID behind the tube sheet in the unrolled area
2. Measure the length of the tube(s) to be cleaned
3. Identify the type of deposit to be removed. (Hard, Soft, Gummy or Powder)
4. Select proper type and size drill and/or brush for the deposit being removed.
5. To select proper size Motor Coupling, Motor Shaft, Gaskets, Extension Couplings, and Extension Shafts refer to the cleaning shaft OD for the drills and/or brushes selected in the right hand column on the following page. Then refer to the shaft OD in the chart above to select the proper components.
6. It is recommended to brush the tubes after they are cleaned with a drill to remove any residual debris and to refine the tube's ID.

NOTE: Although Motor Shafts are available in lengths of up to 18 feet (5.5M) they are not readily available. Motor and Extension shafting are readily available in 5' (1.5M) and 10' (3M) lengths for handling, storage and shipping purposes. (Maximum length to ship UPS is 5' (1.5M)).

MAINTENANCE INSTRUCTIONS

CARE & MAINTENANCE:

This cleaning motor should give good performance for many hours under extreme load provided that it is supplied with proper lubrication as described in the Operating Instructions on page 4. All rotating parts are mounted on ball bearings, which are either pre-lubricated or get their lubrication from the air stream. The paddles (10) are considered a standard replacement item as they receive the most wear. A loss of power is a strong indication of paddle wear. To replace the paddles, remove the Body Bolt Nuts (40) and the Body Cap Screws (41) and remove the Exhaust End (5). Then remove the Shaft (9), Ball Thrust Bearings (11), and Ball Thrust Plates (12). Inspect the bearings and thrust plates for wear and replace if necessary. Remove the worn paddles and replace with the new set (4 req'd. per set). Reassemble in reverse order. Should this not restore the power to its original state, check "Troubleshooting" on page 6. If solution still cannot be found, motor may have to be returned to the factory for evaluation.

1. Excessive leakage of air around the trigger (35) or the unit not shutting off indicates worn O-Ring (32) or worn Trigger Valve Assembly (31).
2. Water leakage around the Shaft (9), or water not shutting off completely, indicates worn O-Rings (21) or worn Water Feed Valve (20).
3. Excessive gear noise with attendant loss of power, due to damaged or worn gears.
4. Motor running rough and causing vibration indicates worn Ball Thrust Bearings (11) and/or Ball Thrust Plates (12).

TROUBLESHOOTING

	Air Leakage	Air Strainers Clogged	Air Pressure Too Low	Dirty Air	Water In Air	Incorrect Lubrication	Insufficient Lubrication	Hose Too Small	Long Paddles*	Worn Paddles	Rotor Rubbing	Worn Bearing Plates	Worn Valve Seat	Throttle Pin Sticking
Motor Will Not Run		X	X				X		X		X			
Lack Of Power	X	X	X			X		X		X	X	X		
Speed Too Low		X	X					X			X			
High Air Consumption	X									X		X		
Excessive Paddle Wear				X		X	X							
Excessive Bearing Wear				X		X	X							
Rusting Of Parts					X	X	X							
Delamination Of Paddles				X	X	X								
Paddles Chipping				X		X	X							
Motor Continues To Run, Throttle Off													X	X

Motors

Pneumatic motors have assemblies built to very close tolerances. Under constant use and with the possibility of foreign parts moving through the air line, these tolerances have a tendency to increase due to vane wear. Air motor maintenance is critical. Dirt should not be allowed to collect around exhaust ports or fitting connections.

*NOTE: If motor is stored in an area of high humidity, vanes may expand in length.

WARRANTY

Should any part, of Seller's own manufacture, prove to have been defective in material or workmanship when shipped (as determined by Seller), Seller warrants that it will, at its sole option, repair or replace said part f.o.b., point of manufacture, provided that Buyer notifies, in writing, of such defect within twelve (12) months from date of shipment from the manufacturing plant.

On request of Seller, the part claimed to be defective will be returned, transportation, insurance, taxes and duties prepaid, to the factory where made, for inspection. Any item, which has been purchased by Seller, is warranted only to the extent of the original manufacturer's warranty to Seller. Seller shall not be liable for any damages or delays caused by defective material or workmanship.

No allowance will be made for repairs or alterations made by others without Seller's written consent or approval. If repairs or alterations are attempted without Seller's consent, Seller's warranty is void.

THE WARRANTIES PROVIDED IN THE OBLIGATIONS AND LIABILITIES OF SELLER HEREUNDER, AND THE RIGHTS AND REMEDIES OF BUYER HEREUNDER ARE EXCLUSIVE AND IN SUBSTITUTION FOR, AND BUYER HEREBY WAIVES ALL OTHER WARRANTIES, GUARANTEES, OBLIGATIONS, CLAIMS FOR LIABILITIES, RIGHTS AND REMEDIES, EXPRESS OR IMPLIED, ARISING BY LAW OR OTHERWISE, INCLUDING BUT NOT LIMITED TO THE IMPLIED WARRANTY FOR MERCHANTABILITY AND FITNESS FOR PURPOSE.

Seller's total liability is limited to the lower of the cost of repair or replacement.

This page intentionally left blank.



Contact Us

Elliott Tool offers a complete line of precision tube tools to meet your needs. Contact us or your local support.

Elliott Tool Technologies, Ltd.
1760 Tuttle Avenue
Dayton, Ohio 45403-3428
Phone: +1 937 253 6133 • +1 800 332 0447
Fax: +1 937 253 9189
www.elliott-tool.com

Printed in the USA
©02/2021 Elliott Tool Technologies, Ltd.
TM-81
PL-43

Locally Supported By:

www.elliott-tool.com/support